

iWASH

OPERATING INSTRUCTIONS
 ISTRUZIONI D'USO
 INSTRUCTIONS POUR L'UTILISATION
 GEBRAUCHSANWEISUNG



IP40  
 MADE IN ITALY



Product for indoor applications.
Prodotto per uso solo interno.
 Produit pour intérieur.
Produkt für den Innenbereich.



Read and retain the instructions.
Leggere e conservare le istruzioni.
 Lisez et conservez ces instructions.
Lesen und bewahren Sie die Anweisungen auf.

Powersupply
Alimentazione
Alimentation
Stromversorgung

Constant voltage
 24Vdc

Max. power consumption
Max. potenza assorbita
Max. puissance
Max. Stromverbrauch

12,5 W/m

Insulation Class
Classe di isolamento
Classe d'isolation
Schutzklasse



Max. weight
Max. peso
Max. poids
Max. Gewicht

340g/meter

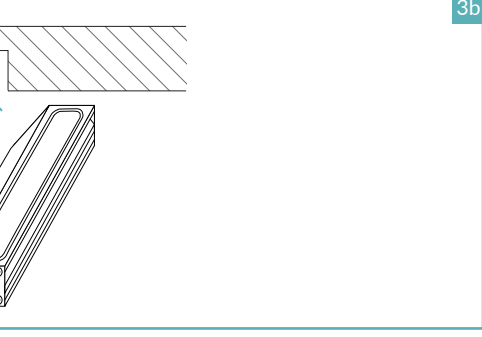
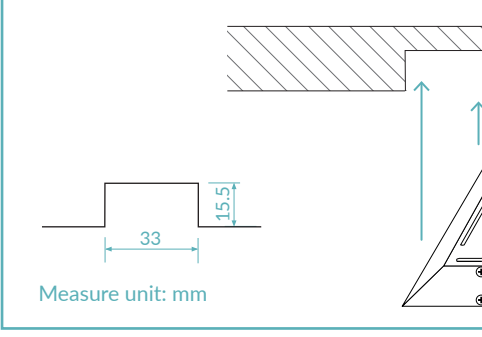
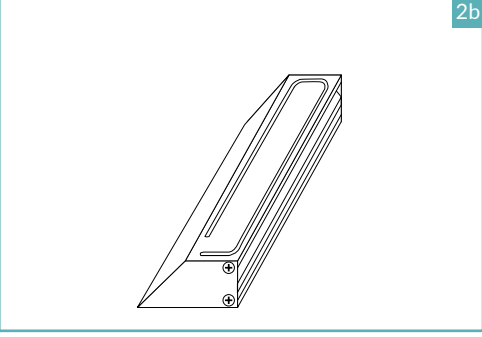
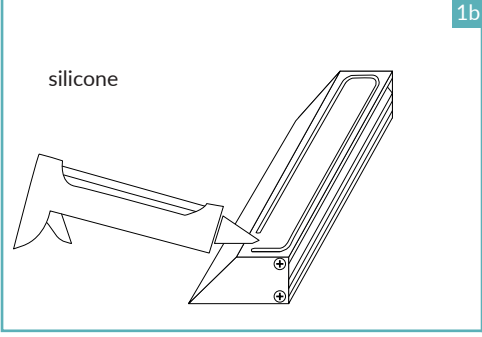
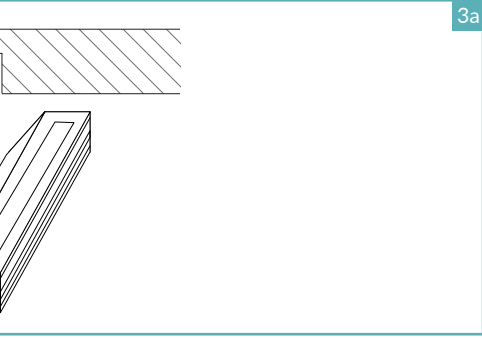
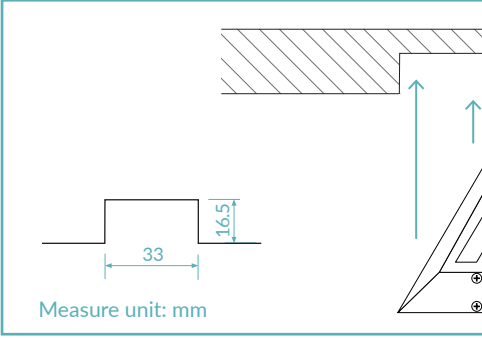
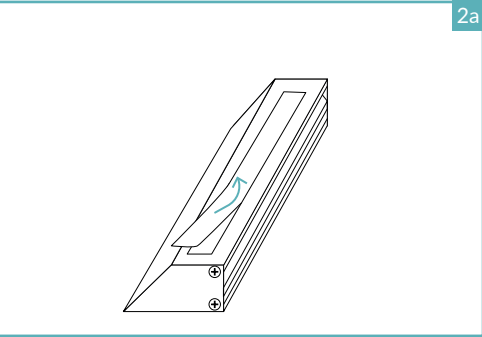
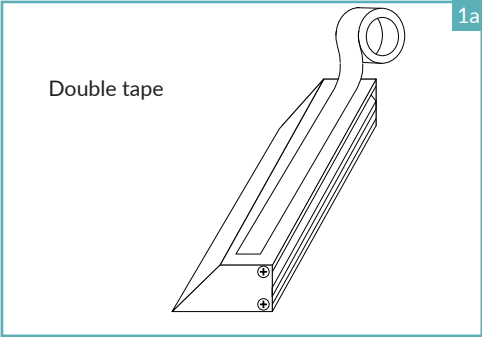

ON / OFF

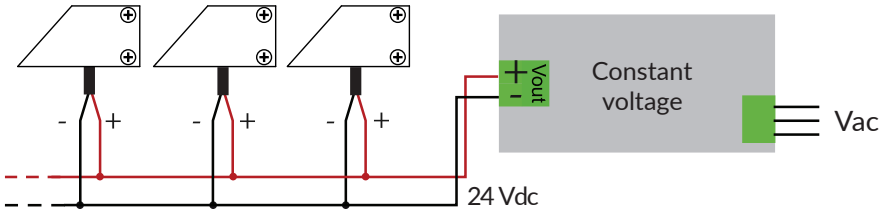

DIMMER

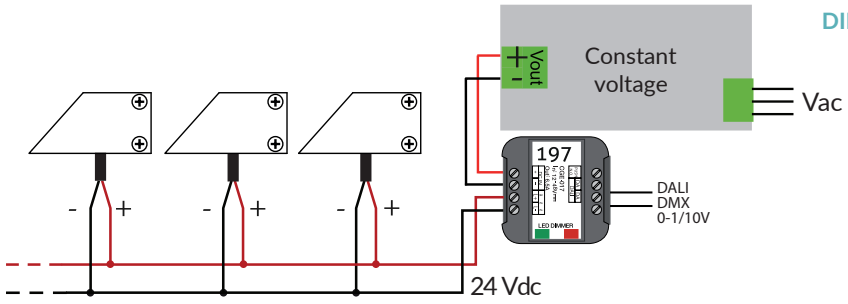



WARNING!

When connecting and disconnecting the device, make sure that the power supply is not powered.

The safety of the appliance is guaranteed by observance of these instructions, therefore it is recommended to keep them.

All assembly, maintenance and replacement operations on the appliance must be carried out making sure that the power is off.

The installation must be carried out by qualified installers in full compliance with the legislation.

ATTENZIONE!

Durante la connessione e la disconnessione dell'apparecchio assicurarsi che l'alimentatore non sia alimentato.

La sicurezza dell'apparecchio é garantita dall'osservanza di queste istruzioni pertanto si raccomanda di conservarle.

Tutte le operazioni di montaggio, manutenzione e sostituzione dell'apparecchio vanno eseguite assicurandosi che la rete di alimentazione sia disinserita.

L'installazione deve essere effettuata da installatori qualificati nel pieno rispetto della normativa.

ATTENTION!

Lors de la connexion et de la déconnexion de l'appareil, assurez-vous que l'alimentation n'est pas alimentée.

La sécurité de l'appareil est garantie par le respect de ces instructions, il est donc recommandé de les conserver.

Toutes les opérations de montage, d'entretien et de remplacement de l'appareil doivent être effectuées en s'assurant que l'alimentation est coupée.

L'installation doit être effectuée par des installateurs qualifiés en pleine conformité avec la législation.

WARNUNG!

Stellen Sie beim Anschließen und Trennen des Geräts sicher, dass die Stromversorgung spannungslos ist.

Die Sicherheit des Gerätes wird durch die Beachtung dieser Anleitung gewährleistet, daher wird empfohlen, sie aufzubewahren.

Bei allen Montage-, Wartungs- und Austauscharbeiten am Gerät muss sichergestellt sein, dass die Stromversorgung unterbrochen ist.

Die Installation muss von qualifizierten Installateuren unter vollständiger Einhaltung der Gesetzgebung durchgeführt werden.

NOTE / NOTA / REMARQUE / NOTIZ

Use only constant voltage power supplies supplied by unonovesette, the use of different power supplies will void the warranty.

Utilizzare esclusivamente alimentatori a tensione costante forniti da unonovesette, l'utilizzo di alimentatori differenti invalida la garanzia.

Utilisez uniquement des alimentations à tension constante fournies par unonovesette, l'utilisation d'alimentations différentes annulera la garantie.

Verwenden Sie nur Konstantspannungsnetzteile von unonovesette, bei Verwendung anderer Netzteile erlischt die Garantie.



unonovesette

Via Galileo Galilei, 15
20856 Correzzana (MB) Italy
(+39) 039 6367340

info@unonovesette.it
unonovesette.it