



VARIO 60

unonovesette
LIGHTING INSTRUMENTS

Vario 60 is an extremely efficient compact LED projector, designed for optical excellence and engineered for complete resilience. Vario 60 offers a choice of three colour temperatures as standard (2700K, 3000K and 4000K) and delivers 90 CRI for excellent colour rendering, and with binning-free LEDs carefully selected from two-step MacAdam's ellipses, colour consistency is assured throughout the unonovesette portfolio. With a deep recess of the inhouse designed PCB, Vario 60 offers excellent glare control. Available with a choice of four beam angles (10°, 30°, 50° and elliptical).

Vario 60 è un apparecchio a LED dalle dimensioni compatte estremamente efficiente. Ideato con un'ottica eccellente e progettato per una completa flessibilità, Vario 60 offre una scelta fra tre temperature di colore standard (2700K, 3000K e 4000K) tutte con CRI maggiore di 90 per una eccellente resa cromatica. Binningfree e due-step MacAdam's ellipses LED, assicurano consistenza del colore in tutte le versioni previste da unonovesette. Con l'elettronica progettata internamente e ben posizionata, Vario 60 offre un eccellente controllo dell'abbagliamento. Disponibile con quattro diverse lenti (10°, 30°, 50° ed ellittica).

NOTE!/NOTA!



Unonovesette srl will not be held responsible if the installation will not be performed in accordance with local standards.

L'azienda unonovesette srl declina ogni responsabilità qualora l'installazione non avvenga secondo le norme vigenti.

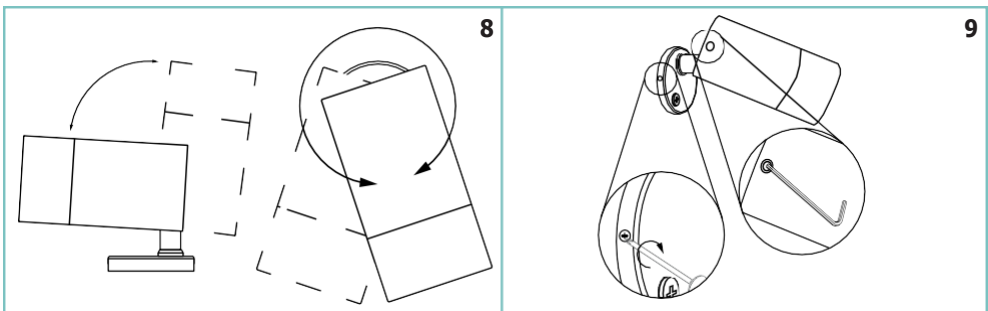
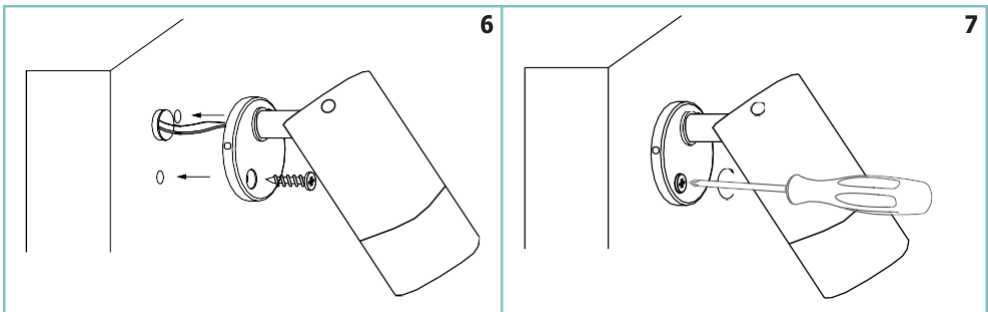
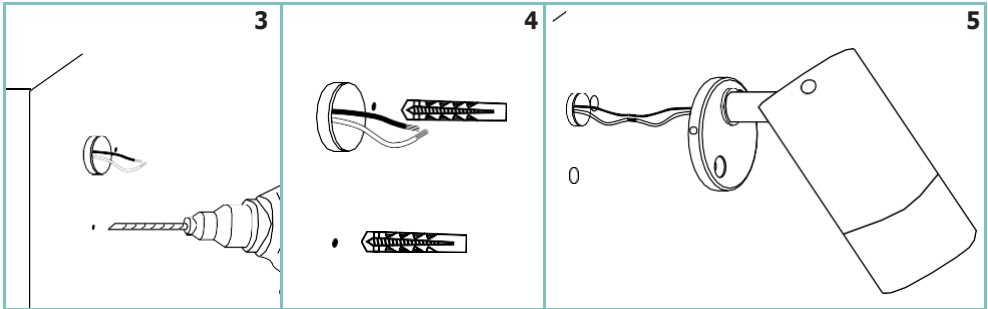
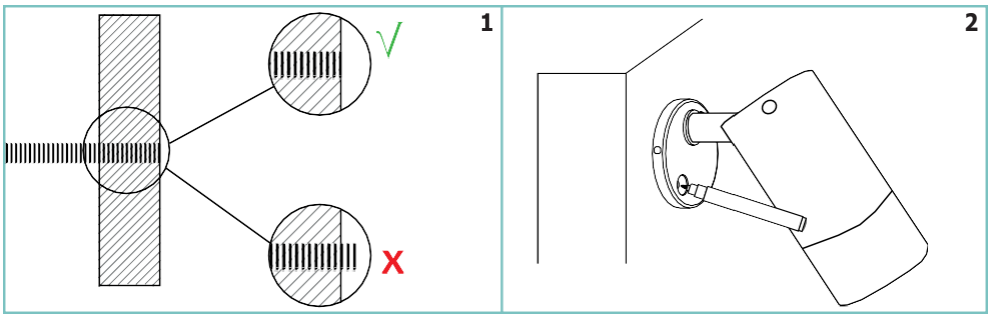

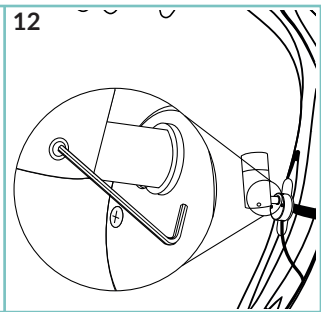
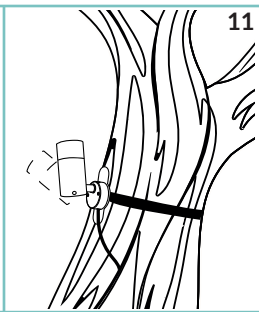
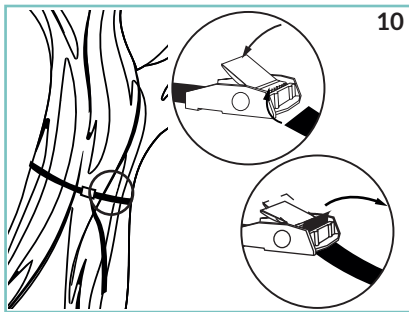
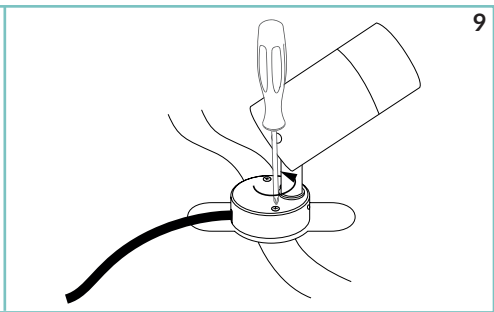
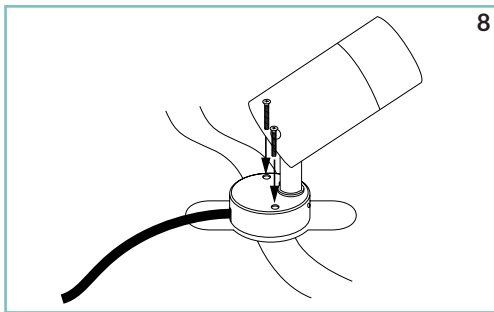
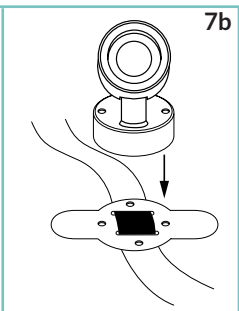
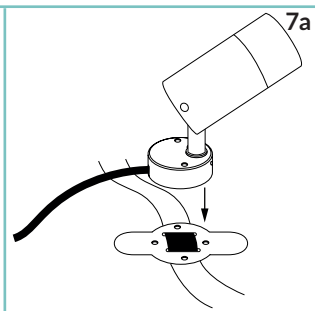
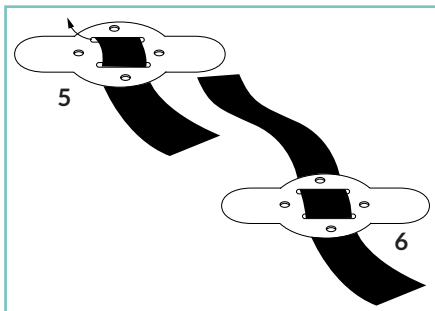
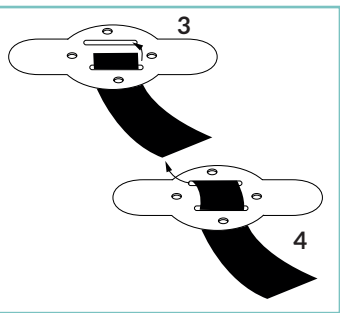
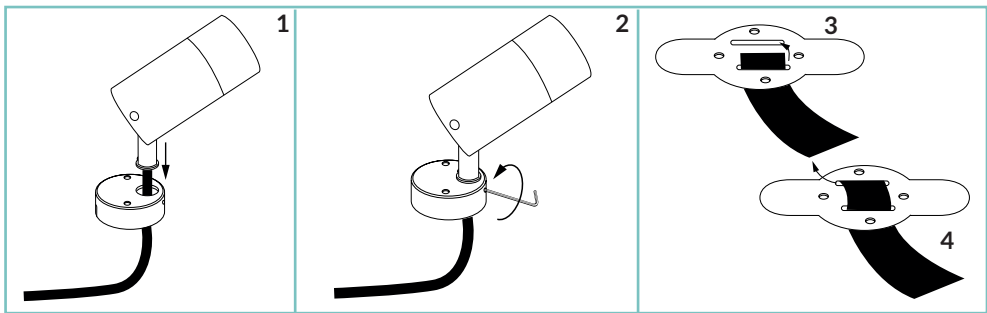

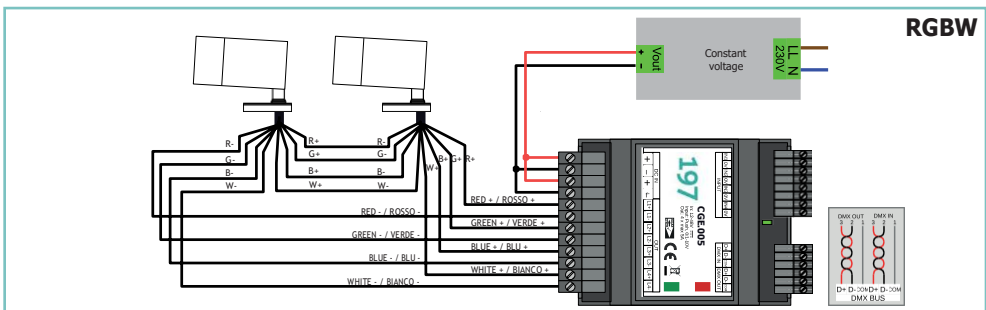
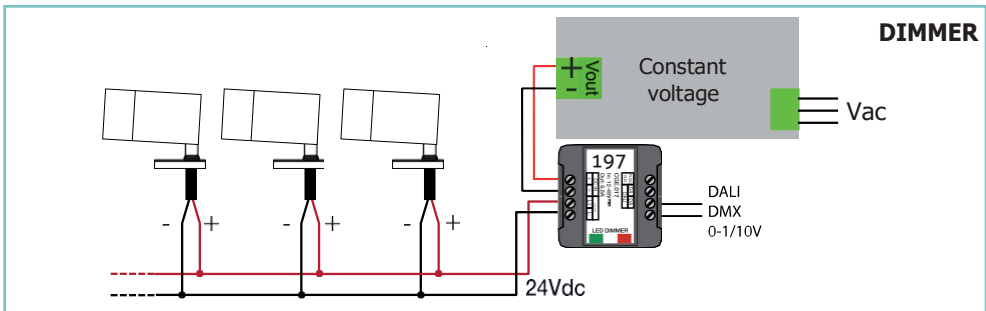
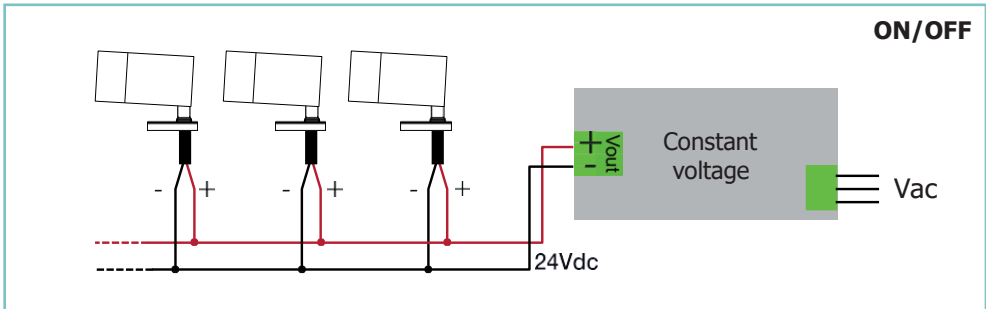
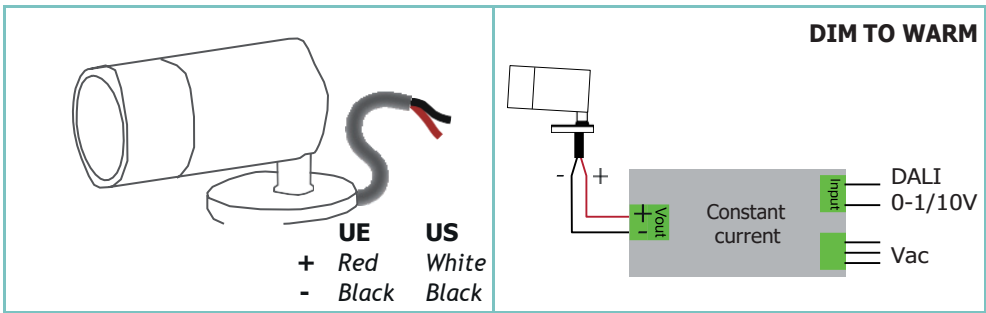

TECHNICAL DATA / SCHEDA PRODOTTO:

Body:	Anodized aluminium 6026 / Machined aged brass	Corpo:	Alluminio anodizzato 6026 / Ottone anticato tornito
Glass:	Extracleartempered 5mm	Vetro:	Temperato extra chiaro 5 mm
Finishes:	Natural anodized / Black anodized / Aged solid brass	Finiture:	Anodizzato naturale / Anodizzato nero / Ottone anticato
Installation:	Surface mounted / Spike / Tree strap	Fissaggio:	Susuperficie / Picchetto / Cinturaperalbero
Power supply cables:	100 cm NS20N PCP 2x0,5 mm ²	Cavo di alimentazione:	100 cm NS20N PCP 2x0,5 mm ²
Power supply:	Constant voltage 24Vdc / 350-14 mA DTW	Alimentazione:	Tensione costante 24vdc / 350-14 mA DTW
Power consumption:	5 Watt / 9 Watt / 11 Watt	Potenza assorbita:	5 Watt / 9 Watt / 11 Watt
CRI:	>90	CRI:	>90
Bin selection:	Binning free 2 step MacAdam's	Selezione bin:	Binning free 2 step MacAdam's
Lumenoutput (source):	515 lm / 730 lm / 840 lm (3000K) / 1045 lm-28 lm (DTW)	Flusso luminoso (sorgente):	515 lm / 730 lm / 840 lm (3000K) / 1045 lm-28 lm (DTW)
Operating temperature:	-20°C +50°C	Temperatura di funzionamento:	-20°C +50°C
IP rating:	IP66	Grado di protezione:	IP66
Insulation class:	Class III	Classe d'isolamento:	Classe III
Impact resistance:	IK08	Protezione impatto:	IK08
Weight:	500 g	Peso:	500 g
Optics:	10° / 30° / 50° / 10°x45° / 45°x10° (20° / 40° DTW) / (35° RGBW)	Ottiche:	10° / 30° / 50° / 10°x45° / 45°x10° (20° / 40° DTW) / (35° RGBW)
Energy rating:	A++	Energy rating:	A++
LED colour temperature:	2700K / 3000K / 4000K / RGBW / (3000K-1800K DTW)	Temperatura colore LED:	2700K / 3000K / 4000K / RGBW / (3000K-1800K DTW)
Lifetime LED:	100000 hrs	Vita media LED:	100000 hrs
Photo biological risk:	RG0 / RG1	Rischio fotobiologico:	RG0 / RG1

WARNING! / ATTENZIONE!



Do not cover the light fixture, make sure it is guaranteed the cooling of the lamp.

Non coprire l'apparecchio, assicurarsi che sia garantito il corretto raffreddamento della lampada.

Never connect or disconnect the fixture when the driver is powered.

Durante la connessione e la disconnessione dell'apparecchio assicurarsi che l'alimentatore non sia alimentato.

The safety of the fitting is guaranteed by the correct use of the following instructions. It is therefore necessary to keep them.

La sicurezza dell'apparecchio é garantita dall'osservanza di queste istruzioni pertanto si raccomanda di conservarle.

When carrying out all assembly, maintenance and fixture replacement operations, make sure that the power is off.

Tutte le operazioni di montaggio, manutenzione e sostituzione dell'apparecchio, vanno eseguite assicurandosi che la rete di alimentazione sia disinserita.

The fitting should be installed by qualified installers to comply with the HD 384 standards.

L'installazione deve essere effettuata da installatori qualificati nel pieno rispetto della normativa.

unonovesette

Via Galileo Galilei, 15
20856, Correzzana (Mb) Italy
+39 039 6367340

info@unonovesette.it
www.unonovesette.it