



AGILE 60 - GU10

OPERATING INSTRUCTIONS

ISTRUZIONI D'USO

INSTRUCTIONS POUR L'UTILISATION

GEBRAUCHSANWEISUNG



IP66 CE ~~X~~

MADE IN ITALY



Product for outdoor applications

Prodotto per uso esterno

Produit pour extérieur

Produkt für Außenanwendungen



Read and retain the instructions.

Leggere e conservare le istruzioni.

Lisez et conservez ces instructions.

Lesen und bewahren Sie die Anweisungen auf.

Powersupply

Alimentazione

Alimentation

Stromversorgung

120/230Vac

50/60 Hz GU10

Socket

Max. power consumption

Max. potenza assorbita

Max. puissance

Max. Stromverbrauch

7,5W Max.

Insulation Class

Classe di isolamento

Classe d'isolation

Schutzklasse



Max. weight

Max. peso

Max. poids

Max. Gewicht

450g

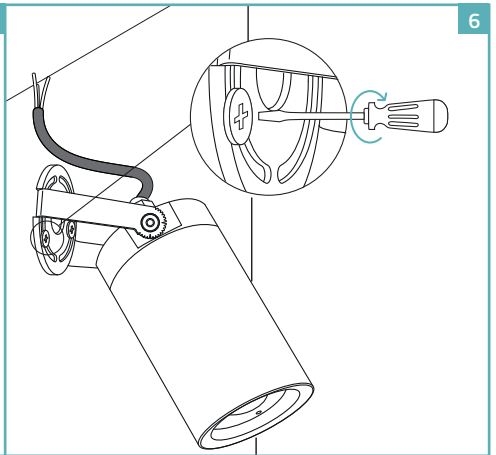
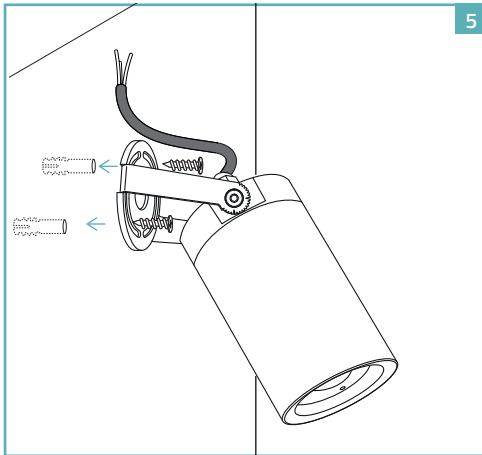
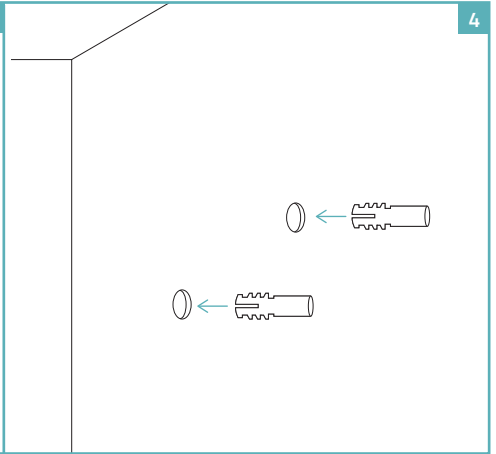
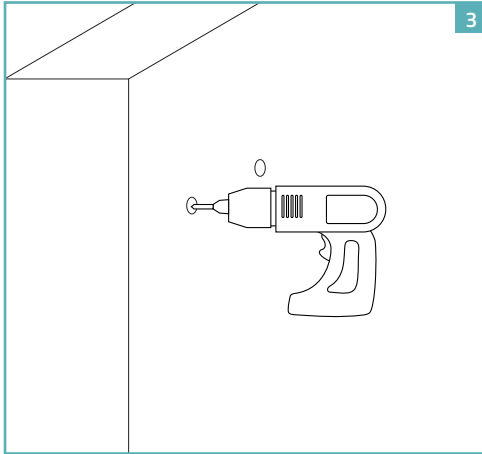
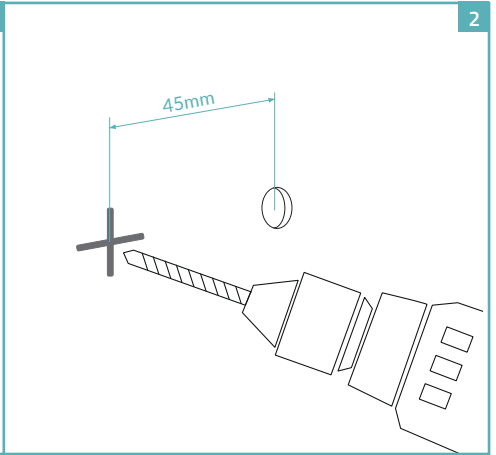
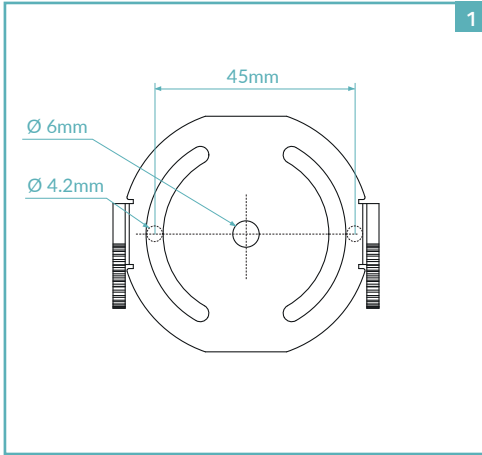

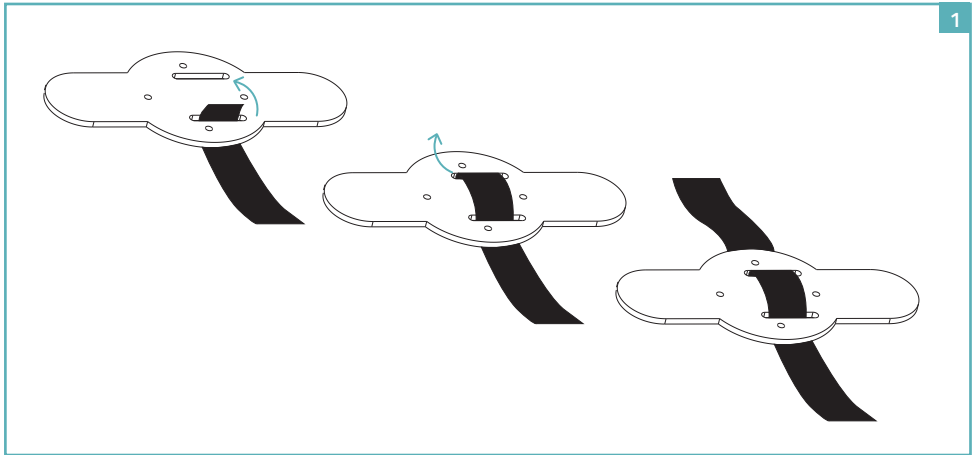
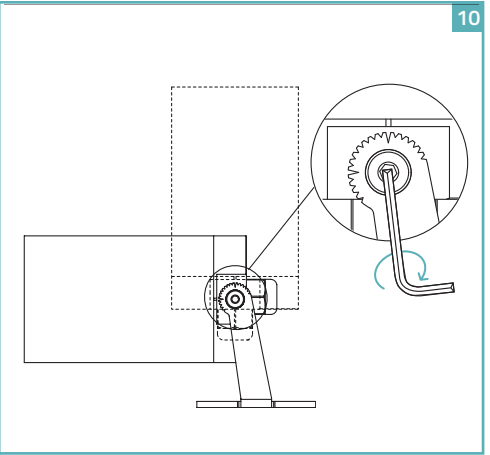
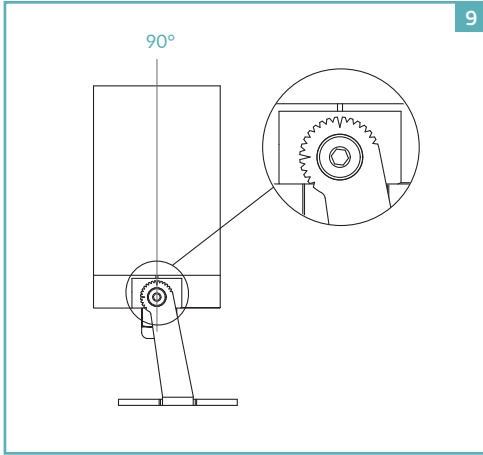
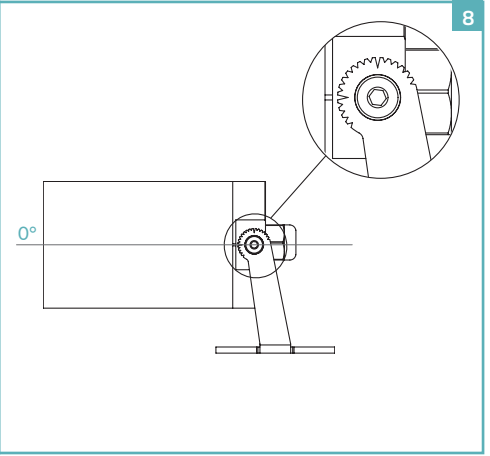
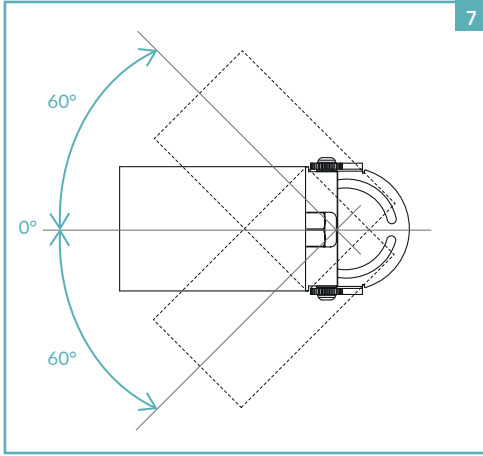

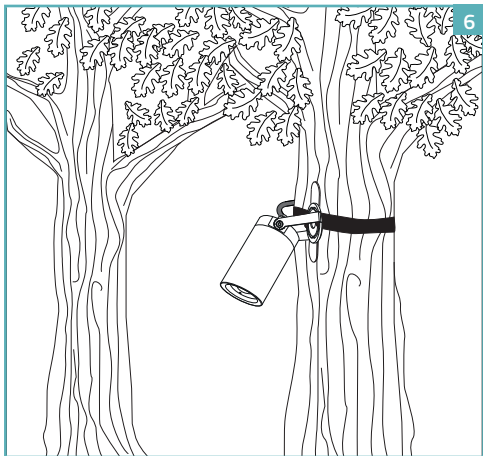
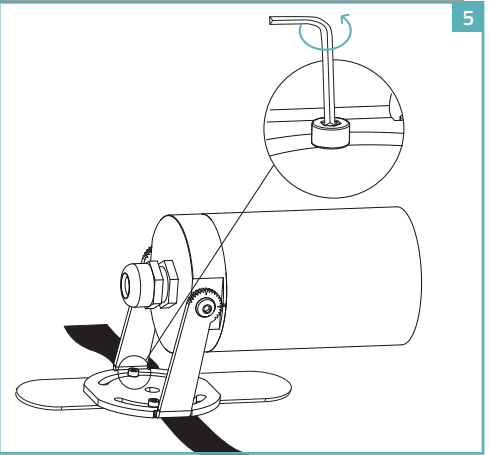
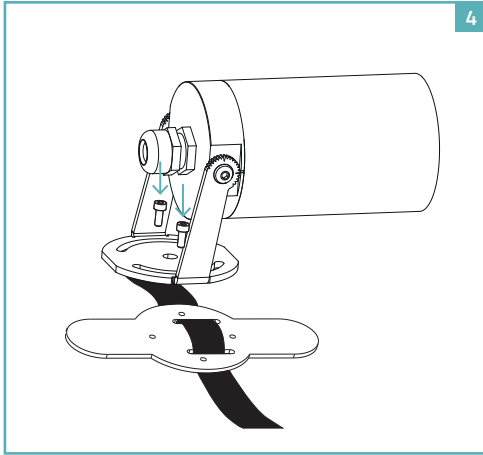
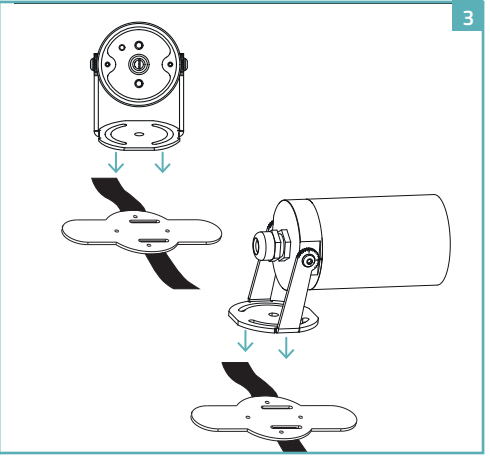
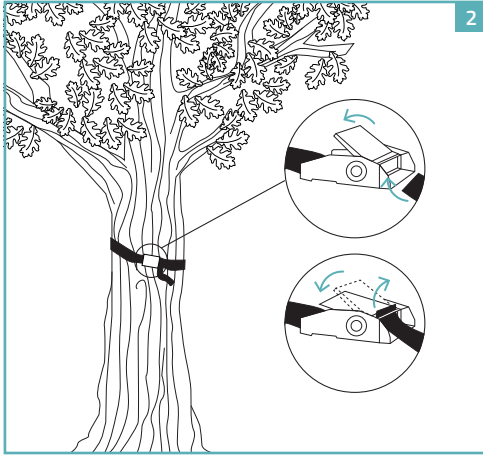

WARNING!



Do not cover the fixture, make sure that the correct cooling of the lamp is guaranteed.

When connecting and disconnecting the device, make sure that the power supply is not powered.

The safety of the appliance is guaranteed by observance of these instructions, therefore it is recommended to keep them.

All assembly, maintenance and replacement operations on the appliance must be carried out making sure that the power is off.

The installation must be carried out by qualified installers in full compliance with the legislation.

ATTENZIONE!

Non coprire l'apparecchio, assicurarsi che sia garantito il corretto raffreddamento della lampada.

Durante la connessione e la disconnessione dell'apparecchio assicurarsi che l'alimentatore non sia alimentato.

La sicurezza dell'apparecchio é garantita dall'osservanza di queste istruzioni pertanto si raccomanda di conservarle.

Tutte le operazioni di montaggio, manutenzione e sostituzione dell'apparecchio vanno eseguite assicurandosi che la rete di alimentazione sia disinserita.

L'installazione deve essere effettuata da installatori qualificati nel pieno rispetto della normativa.

ATTENTION!

Ne couvrez pas le luminaire, assurez-vous que le refroidissement correct de la lampe est garanti.

Lors de la connexion et de la déconnexion de l'appareil, assurez-vous que l'alimentation n'est pas alimentée.

La sécurité de l'appareil est garantie par le respect de ces instructions, il est donc recommandé de les conserver.

Toutes les opérations de montage, d'entretien et de remplacement de l'appareil doivent être effectuées en s'assurant que l'alimentation est coupée.

L'installation doit être effectuée par des installateurs qualifiés en pleine conformité avec la législation.

WARNUNG!

Decken Sie die Leuchte nicht ab, stellen Sie sicher, dass die richtige Kühlung der Lampe gewährleistet ist.

Stellen Sie beim Anschließen und Trennen des Geräts sicher, dass die Stromversorgung spannungslos ist.

Die Sicherheit des Gerätes wird durch die Beachtung dieser Anleitung gewährleistet, daher wird empfohlen, sie aufzubewahren.

Bei allen Montage-, Wartungs- und Austauscharbeiten am Gerät muss sichergestellt sein, dass die Stromversorgung unterbrochen ist.

Die Installation muss von qualifizierten Installateuren unter vollständiger Einhaltung der Gesetzgebung durchgeführt werden.

NOTE / NOTA / REMARQUE / NOTIZ



Use only constant voltage power supplies supplied by unonovesette, the use of different power supplies will void the warranty.

Utilizzare esclusivamente alimentatori a tensione costante forniti da unonovesette, l'utilizzo di alimentatori differenti invalida la garanzia.

Utilisez uniquement des alimentations à tension constante fournies par unonovesette, l'utilisation d'alimentations différentes annulera la garantie.

Verwenden Sie nur Konstantspannungsnetzteile von unonovesette, bei Verwendung anderer Netzteile erlischt die Garantie.

unonovesette

Via Galileo Galilei, 15
20856 Correzzana (MB) Italy
(+39) 039 6367340

info@unonovesette.it
www.unonovesette.it