











IP68

FELIX 40 SUB

Felix 40 sub is an extremely efficient compact IP68 surface mounted stainless steel LED projector, designed for optical excellence and engineered for complete resilience. Felix 40 sub offers a choice of four colour temperatures as standard (2200K, 2700K, 3000K and 4000K) and delivers 90 CRI for excellent colour rendering, and with binning-free LEDs carefully selected from two-step MacAdam's ellipses, colour consistency is assured throughout the unonovesette portfolio. With a deep recess of the in-house designed PCB, Felix 40 sub offers excellent glare control.

Le Felix 40 sub est un projecteur IP68 à LED compact très efficace. Il est conçu avec d'excellentes optiques et pour une flexibilité complète. Le Felix 40 sub donne un choix de quatre températures de couleur (2200K, 2700K, 3000K, 4000K) avec IRC >90 pour un excellent rendu des couleurs Binning-free et 2 step MacAdam garantissent la cohérence des couleurs dans toutes les versions fournies par unonovesette. Avec une électronique conçue en interne et bien positionnée, le Felix 40 sub offre un excellent contrôle de l'éblouissement.

TECHNICAL DATA / FICHE TECHNIQUE:

-  IP68
-  2W
-  140 lm (3000K)
-  >90
- 
-  2200K / 2700K / 3000K / 4000K
-  10° / 23° / 43° / 10°x40° / 40°x10°
-  Smart Shield

FINISHES / FINITIONS:

-  Stainless steel AISI316L
Acier INOX AISI316L

OPTICS / FAISCEAU:

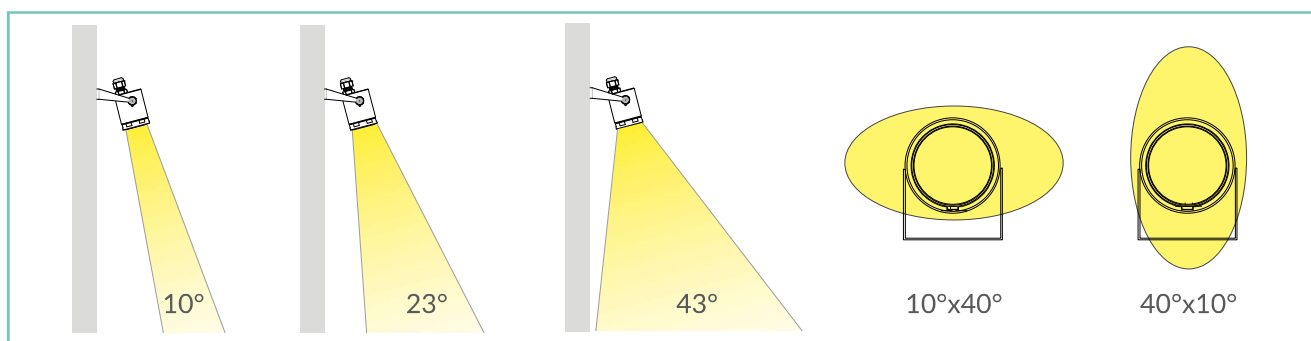

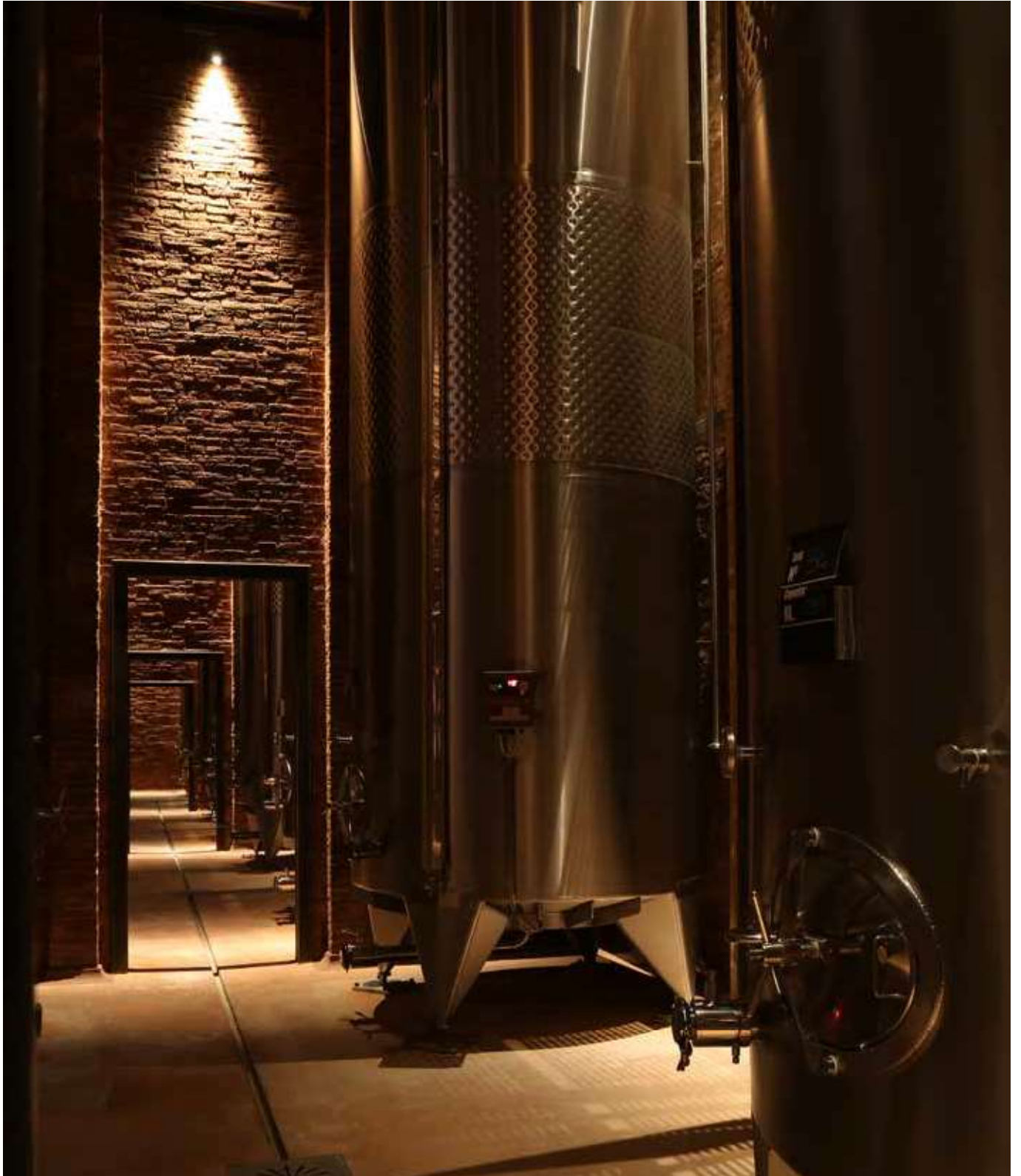

unonovesette

PRODUCT CODE/CODE PRODUIT:

F40 = FELIX 40 SUB 	Select one component from each column to specify a complete configuration: Sélectionner un composant pour chaque colonne pour une configuration complète:		
	LED colour / Couleur LED 22 = 2200K 27 = 2700K 30 = 3000K 40 = 4000K	Optics / Faisceau N = 10° M = 23° W = 43° E = 10°x40° X = 40°x10°	Finish / Finitions 03 = Stainless steel AISI316L / Acier INOX AISI316L

Standard configuration example/
 Exemple de configuration standard:

F40.30.N.03 Felix 40 sub 3000K 10° optics stainless steel / Acier INOX

POWER SUPPLIES 24Vdc CONSTANT VOLTAGE / ALIMENTATEUR TENSION CONSTANTE 24Vdc:

On / Off 18W

Code / Code	Input	I Out	V Out	Watt	IP	#Tracer 60
PSU.CV.005	90÷305V / 47/63 Hz	1 A	24Vdc	25	IP67	Max 1
PSU.CV.006	90÷305V / 47/63 Hz	2,5 A	24Vdc	60	IP67	Max 2
PSU.CV.007	90÷305V / 47/63 Hz	3,75 A	24Vdc	90	IP67	Max 4
PSU.CV.021	90÷305V / 47/63 Hz	10 A	24Vdc	240	IP67	Max 11

Control gear / Elettronica di controllo 18W

Code / Code	Input	I Out	V Out	Watt	IP	#Tracer 60
CGE.004 - 0/1-10V	24Vdc	6,5 A	24Vdc	156	IP20	Max 7
CGE.017 - DALI	24Vdc	6,5 A	24Vdc	156	IP20	Max 7
CGE.017.IP - DALI	24Vdc	6,5 A	24Vdc	156	IP67	Max 7
CGE.020 - DMX	24Vdc	6,5 A	24Vdc	156	IP20	Max 7

ACCESSORIES / ACCESSOIRES

 Honeycomb louver Schermo alveolare ACC.084	 Anti-Glare louver Frangiluce ACC.008	 CV00040 CV00041 CV00042 CV00043	 Cable Cavo 10m 15m 20m 25m ACC.092 ACC.092.050 ACC.092.100 ACC.092.150	Ground spike Piquet 35cm 50cm 100cm 150cm
---	---	--	--	--

TECHNICAL DRAWING / DESSIN TECHNIQUE:

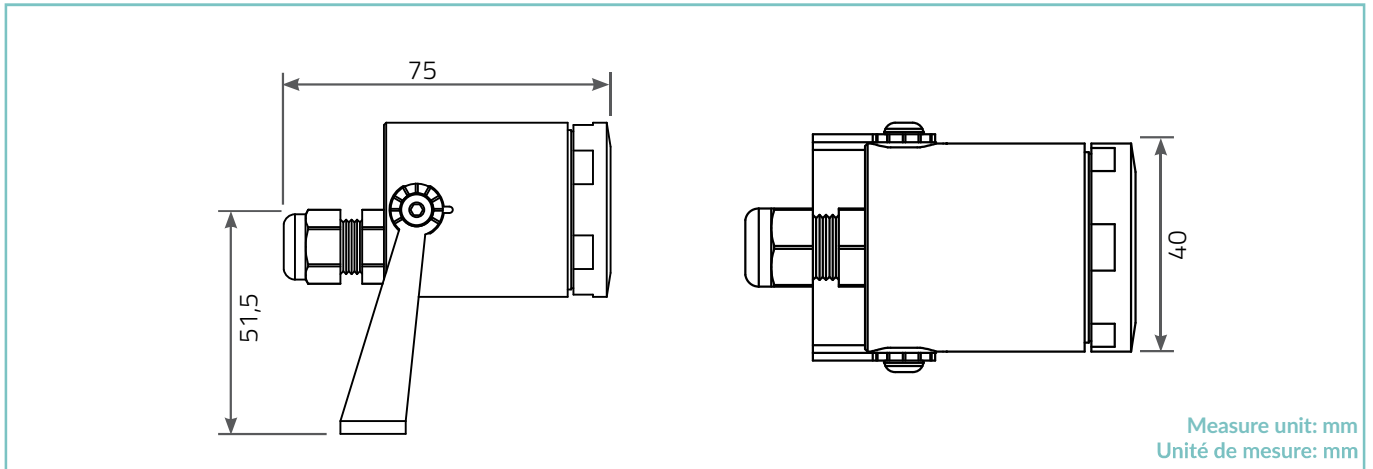

Measure unit: mm
Unité de mesure: mm



TECHNICAL SHEET / FICHE PRODUIT:

Body: Stainless Steel AISI316L
Glass: Tempered extra clear glass 4 mm
Finishes: Stainless Steel AISI316L
Installation: Surface mounted / Ground spike
Power supply cables: 500cm NS20N PCP 2x0,5 mm²
Power supply: Constant voltage 24Vdc
Power consumption: 2 Watt
CRI: >90
Bin selection: Binning free 2 step MacAdam's
Lumenoutput (source): 140 lm (3000K)
Operating temperature: -20°C +50°C
IP rating: IP68 (5 meter underwater)
Insulation class: Class III
Impact resistance: IK07
Weight: 410 g
Optics: 10° / 23° / 43° / 10°x40° / 40°x10°
LED colour temperature: 2200K / 2700K / 3000K / 4000K
Lifetime LED: 100000 hrs
Photo biological risk: RGO / RG1

Corps: Acier INOX AISI316L
Verre: Verre extra clair 4 mm
Finitions: Acier INOX AISI316L
Installation: Surface / Piquet
Câbles d'alimentation: 500cm NS20N PCP 2x0,5 mm²
Alimentation: Tension constante 24Vdc
Puissance absorbée: 2 Watt
IRC Indice de Rendu des Couleurs: >90
Sélection du bin: Binning free 2 step MacAdam's
Flux de la source: 140 lm (3000K)
Température de fonctionnement: -20°C +50°C
Indice de protection: IP68 (5 mètres sous l'eau)
Classe d'isolation: Classe III
Indice de résistance: IK07
Poids: 410 g
Optiques: 10° / 23° / 43° / 10°x40° / 40°x10°
Couleur LED: 2200K / 2700K / 3000K / 4000K
Durée moyenne LED: 100000 hrs
Sécurité photobiologique: RGO / RG1

PHOTOMETRICS / COURVES PHOTOMETRIQUE:

10° - 2 Watt

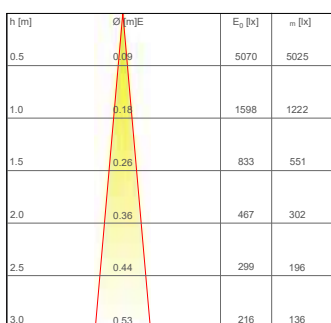

— C0 - C180 (10,0°)

23° - 2 Watt

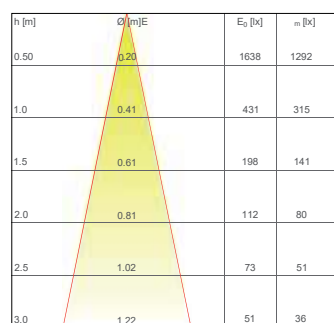

— C0 - C180 (23,0°)

43° - 2 Watt

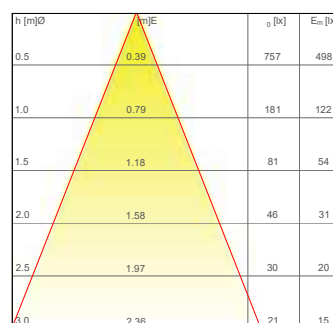

— C0 - C180 (43,0°)

10°x40° - 2 Watt

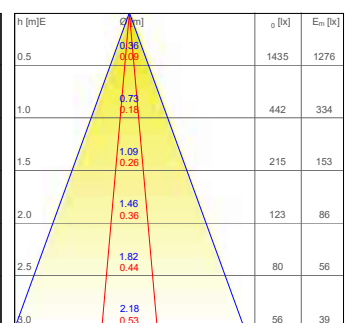

— C0 - C180 (10,0°) — C90 - C270 (40,0°)