











IP68

CALIBER 25 XS



Caliber 25 XS is an extremely efficient miniature in-ground LED up-light with a height of only 35mm, designed for optical excellence and engineered for complete resilience. Caliber 25 XS renders an additional draining system as unnecessary. Caliber 25 XS offers a choice of four colour temperatures as standard (2200K, 2700K, 3000K and 4000K) and delivers 90CRI for excellent colour rendering, and with binning-free LEDs carefully selected from two-step MacAdam's ellipses, colour consistency is assured throughout the unonovesette portfolio.

Caliber 25 XS è un apparecchio a LED dalle dimensioni ridotte, con un'altezza di solo 35mm da incasso a pavimento ed estremamente efficiente. Ideato con un'ottica eccellente e progettato per una completa flessibilità. Caliber 25 XS non necessita di sistema di drenaggio dell'acqua. Caliber 25 XS offre una scelta fra quattro temperature di colore come standard (2200K, 2700K, 3000K e 4000K) tutte con CRI maggiore di 90 per una eccellente resa cromatica. Binning-free e due-step MacAdam's ellipses LED, assicurano consistenza del colore in tutte le versioni previste da unonovesette.

TECHNICAL DATA / DATI TECNICI:

 IP68	 2200K / 2700K / 3000K / 4000K
 1W	 10° / 40° / Satin
 110 lm (3000K)	
 A++	 Smart Shield
 >90	

FINISHES / FINITURE:

	Stainless steel AISI316L Acciaio INOX AISI316L
	Black anodized Anodizzato nero
	Natural anodized Alluminio anodizzato

OPTICS / OTTICHE:

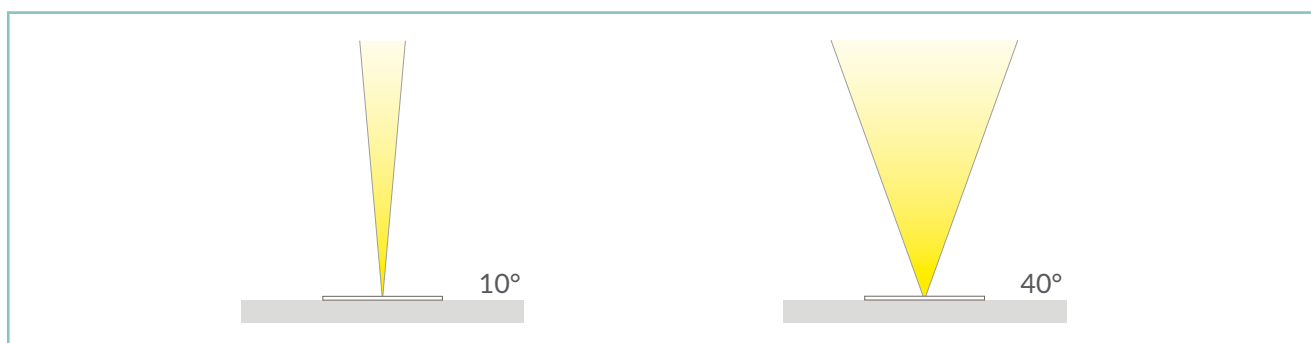

unonovasette



unonovesette

PRODUCT CODE / CODICE PRODOTTO:

CXS = CALIBER25 XS 	Select one component from each column to specify a complete configuration: Selezionare un componente per ogni colonna per la configurazione completa:		
	LED colour / Colore LED 22 = 2200K 27 = 2700K 30 = 3000K 40 = 4000K	Optics / Ottiche N = 10° W = 40° S = Satin/Satinato	Finish / Finiture 03 = Stainless steel/ Acciaio INOX AISI316L 05 = Black anodized / Anodizzato Nero 07 = Natural anodized / Anodizzato naturale

Standard configuration example/
 Esempio di configurazione standard: **CXS.30.N.03 Caliber 25 XS 3000K 10° optics stainless steel / Acciaio INOX**

POWER SUPPLIES 350mA CONSTANT CURRENT / ALIMENTATORE CORRENTE COSTANTE 350mA:



On / Off

Code / Codice	Input	I Out	V Out	Watt	IP	#Caliber XS
PSU.CC.002	100+240V / 50/60 Hz	350mA	36 V	12	IP20	Max 9
PSU.CC.003	100+240V / 50/60 Hz	350mA	43 V	15	IP20	Max 12
PSU.CC.014	100+240V / 50/60 Hz	350mA	24 V	8	IP20	Max 6
PSU.CX.004	110+240V / 50/60 Hz	350mA	43 V	15	IP20	Max 12

Dimmable / Dimmerabile

Code / Codice	Input	I Out	V Out	Watt	IP	#Caliber XS
PSU.CX.001 1-10V/PUSH	110+240V / 50/60 Hz	350mA	47 V	15	IP20	Max 12
PSU.CX.002 DALI	110+240V / 50/60 Hz	350mA	47 V	15	IP20	Max 12

ACCESSORIES / ACCESSORI

 <p>Housing Box Cassaforma HB.005 (10 g)</p>	 <p>Fixing springs Molle di fissaggio ACC.049</p>	 <p>Cable Cavo 5m 10m 15m 20m 25m</p> <p>CV00037 CV00040 CV00041 CV00042 CV00043</p>
---	--	---

CALIBER 25 XS

TECHNICAL DRAWING / DISEGNO TECNICO:

RECESSED HOLE / FORO INCASSO:

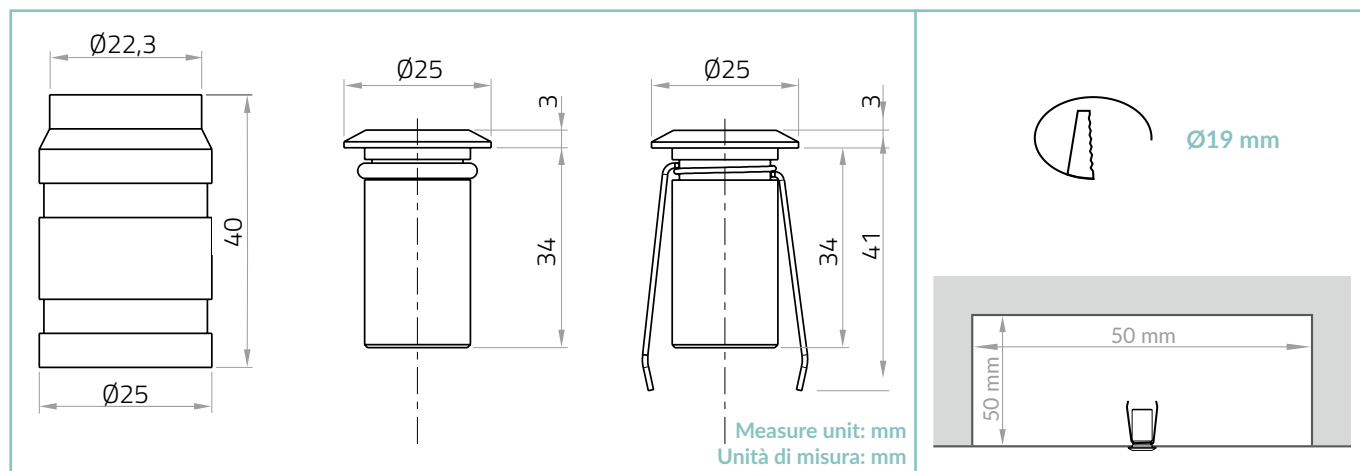

TECHNICAL SHEET / SCHEDA PRODOTTO:

Body: Stainless Steel AISI316L - Anodized aluminium 6026
Glass: Extra clear / frosted glass 2mm
Finishes: Stainless Steel AISI316L / Black anodized / Natural anodized
Installation: Housing box / Fixing Springs
Power supply cables: 35 cm NS20N PCP 2x0,5 mm²
Power supply: Constant Current 350mA Max
Power consumption: 1 Watt
CRI: >90
Bin selection: Binning free 2 step MacAdam's
Lumenoutput (source): 110 lm (3000K)
Operating temperature: -20°C +50°C
IP rating: IP68 (not for permanent immersion)
Insulation class: Class III
Impact resistance: IK05
Weight: 50 g
Optics: 10° / 40° / Satin
Energy rating: A++
LED colour temperature: 2200K / 2700K / 3000K / 4000K
Lifetime LED: 100000 hrs
Photo biological risk: RGO / RG1

Corpo: Acciaio INOX AISI316L - Alluminio 6026 anodizzato
Vetro: Vetro extra chiaro / satinato 2 mm
Finiture: Acciaio INOX AISI316L / Anodizzato Nero / Anodizzato Naturale
Fissaggio: Cassaforma / Molle di fissaggio
Cavo di alimentazione: 35 cm NS20N PCP 2x0,5 mm²
Alimentazione: Corrente costante 350mA Max
Potenza assorbita: 1 Watt
CRI: >90
Selezione bin: Binning free 2 step MacAdam's
Flusso luminoso (sorgente): 110 lm (3000K)
Temperatura di funzionamento: -20°C +50°C
Grado di protezione: IP68 (non per immersione permanente)
Classe d'isolamento: Classe III
Protezione impatto: IK05
Peso: 50 g
Ottiche: 10° / 40° / Satinato
Energy rating: A++
Temperatura colore LED: 2200K / 2700K / 3000K / 4000K
Vita media LED: 100000 hrs
Rischio fotobiologico: RGO / RG1

PHOTOMETRICS / CURVE FOTOMETRICHE:

10° - 1 Watt

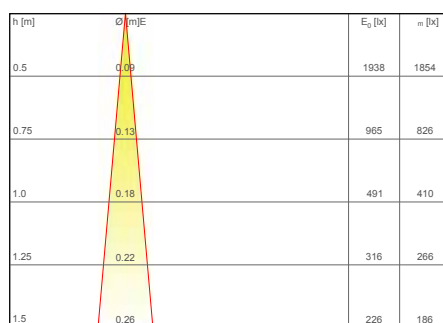

40° - 1 Watt

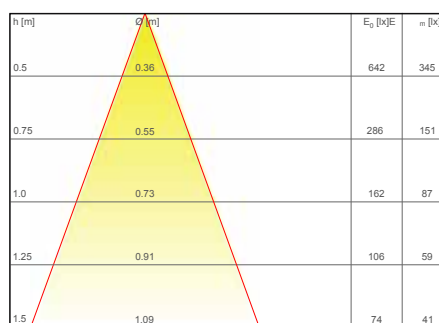

— CO - C180 (10,0°)

— CO - C180 (40,0°)