



IP68

## CALIBER 80 Q

Caliber 80 Q is an extremely efficient compact in-ground LED uplight, designed for optical excellence and engineered for complete resilience. Caliber 80 Q offers a choice of three colour temperatures as standard (2700K, 3000K and 4000K) and delivers 90 CRI for excellent colour rendering, and with binning-free LEDs carefully selected from two-step MacAdam's ellipses, colour consistency is assured throughout the unonovesette portfolio. With a deep recess of the in-house designed PCB, Caliber 80 Q offers excellent glare control. Available with a choice of three beam angles (10, 30 and 50°) and satin.

*Caliber 80 Q è un apparecchio a LED dalle dimensioni compatte da incasso a pavimento ed estremamente efficiente. Ideato con un'ottica eccellente e progettato per una completa flessibilità. Caliber 80 Q offre una scelta fra tre temperature di colore come standard (2700K, 3000K e 4000K) tutte con CRI maggiore di 90 per una eccellente resa cromatica. Binning-free e due-step MacAdam's ellipses LED, assicurano consistenza del colore in tutte le versioni previste da unonovesette. Con l'elettronica progettata internamente e ben posizionata, Caliber 80 Q offre un eccellente controllo dell'abbagliamento. Disponibile con tre diverse lenti (10°, 30° e 50°) e satinato.*

### TECHNICAL DATA / DATI TECNICI:

 IP68

 5W / 9W

 515 lm / 730 lm (3000K)

 >90



 2700K / 3000K / 4000K / RGBW

 10° / 30° / 50° / (35° RGBW)

 Smart Shield

### FINISHES / FINITURE:

 Stainless steel AISI316L  
Acciaio INOX AISI316L

### OPTICS / OTTICHE:

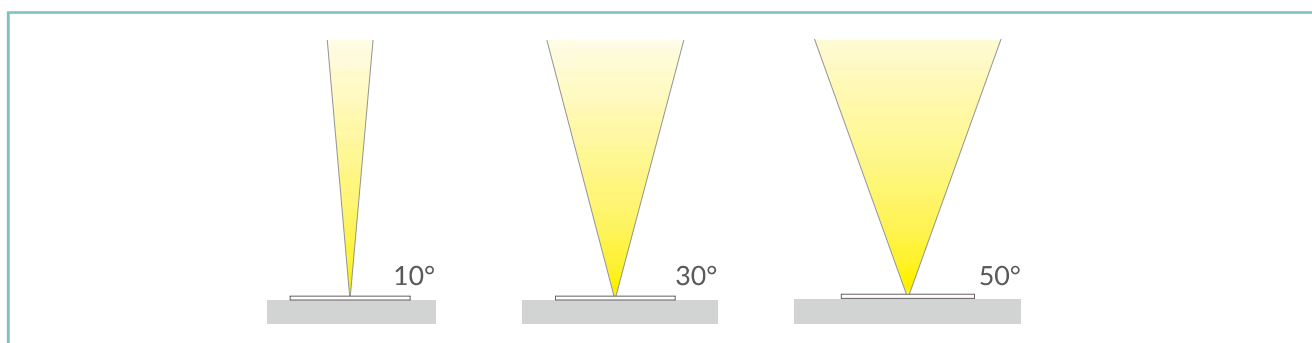



# unonovesette

## PRODUCT CODE / CODICE PRODOTTO:

C8Q = CALIBER 80 Q		Select one component from each column to specify a complete configuration: Selezionare un componente per ogni colonna per la configurazione completa:			
		LED colour / Colore LED	Optics / Ottiche	Finish / Finiture	Watt
		27 = 2700K 30 = 3000K 40 = 4000K FC = RGBW	N = 10° M = 30° (35° RGBW) W = 50° S = Satin/Satinato	03 = Stainless steel AISI316L / Acciaio INOX AISI316L	05 = 5 W 09 = 9 W

Standard configuration example/  
Esempio di configurazione standard:

**C8Q.30.N.03.09** Caliber 80 Q 3000K 10° optics stainless steel / Acciaio INOX 9 Watt

## POWER SUPPLIES 24Vdc CONSTANT VOLTAGE / ALIMENTATORE TENSIONE COSTANTE 24Vdc:

On / Off 9W

Code / Codice	Input	I Out	V Out	Watt	IP	#Caliber 80 Q
PSU.CX.004	110+240V / 50/60 Hz	0,9 A	24Vdc	20	IP20	Max 2
PSU.CV.005	90+305V / 47/63 Hz	1 A	24Vdc	25	IP67	Max 2
PSU.CV.006	90+305V / 47/63 Hz	2,5 A	24Vdc	60	IP67	Max 5
PSU.CV.007	90+305V / 47/63 Hz	3,75 A	24Vdc	90	IP67	Max 8
PSU.CV.021	90+305V / 47/63 Hz	10 A	24Vdc	240	IP67	Max 20

Control gear / Elettronica di controllo 9W

Code / Codice	Input	I Out	V Out	Watt	IP	#Caliber 80 Q
CGE.004 - 0/1-10V	24Vdc	6,5 A	24Vdc	156	IP20	Max 14
CGE.017 - DALI	24Vdc	6,5 A	24Vdc	156	IP20	Max 14
CGE.017.IP - DALI	24Vdc	6,5 A	24Vdc	156	IP67	Max 14
CGE.020 - DMX	24Vdc	6,5 A	24Vdc	156	IP20	Max 14

Control gear / Elettronica di controllo RGBW

Code / Codice	Input	I Out	V Out	Watt	IP	#Caliber 80 Q
CGE.005 - DMX RGBW	24Vdc	4x700 mA	24Vdc	67,2	IP20	Max 6

## ACCESSORIES/ACCESSORI

					
Housing Box Cassaforma HB.003 (170 g)	Housing Box Cassaforma HB.014 (320 g)	Fixing springs Molle di fissaggio ACC.007	Honeycomb louver Schermo alveolare ACC.004	Cable Cavo CV00037 5m CV00040 10m CV00041 15m CV00042 20m CV00043 25m	

TECHNICAL DRAWING / DISEGNO TECNICO:

RECESSED HOLE / FORO INCASSO:

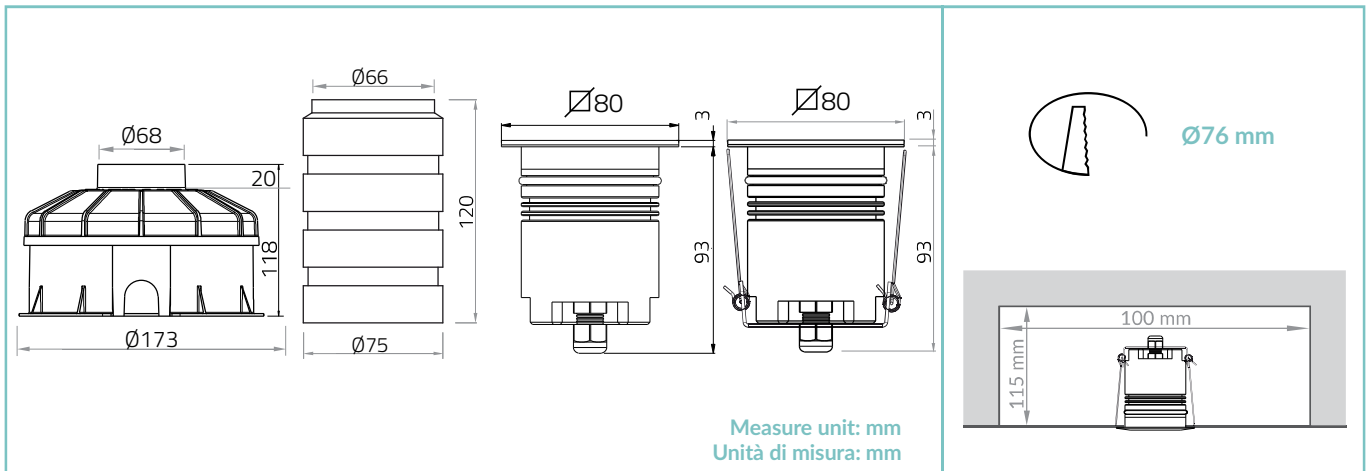

TECHNICAL SHEET / SCHEDA PRODOTTO:

**Body:** Stainless Steel AISI316L - Anodized aluminium 6026  
**Glass:** Tempered extra clear / frosted glass 6 mm  
**Finishes:** Stainless Steel AISI316L  
**Installation:** Housing box / Fixing Springs  
**Power supply cables:** 35 cm NS20N PCP 2x0,5 mm<sup>2</sup>  
 35 cm 8x0,22 mm<sup>2</sup> (RGBW)  
**Power supply:** Constant voltage 24Vdc  
 Constant current 700mA (RGBW)  
**Power consumption:** 5 Watt / 9 Watt  
**CRI:** >90  
**Bin selection:** Binning free 2 step MacAdam's  
**Lumen Output (source):** 515 lm / 730 lm (3000K)  
**Operating temperature:** -20°C +50°C  
**IP rating:** IP68 (not for permanent immersion)  
**Insulation class:** Class III  
**Impact resistance:** IK08  
**Weight:** 640 g  
**Optics:** 10° / 30° / 50° / (35° RGBW) / Satin  
**LED colour temperature:** 2700K / 3000K / 4000K / RGBW  
**Lifetime LED:** 100000 hrs  
**Photo biological risk:** RG0 / RG1

**Corpo:** Acciaio INOX AISI316L - Alluminio anodizzato 6026  
**Vetro:** Vetro temperato extra chiaro o satinato 6 mm  
**Finiture:** Acciaio INOX AISI316L  
**Fissaggio:** Cassaforma / Molle di fissaggio  
**Cavo di alimentazione:** 35 cm NS20N PCP 2x0,5 mm<sup>2</sup>  
 35 cm 8x0,22 mm<sup>2</sup> (RGBW)  
**Alimentazione:** Constant voltage 24Vdc  
 Constant current 700mA (RGBW)  
**Potenza assorbita:** 5 Watt / 9 Watt  
**CRI:** >90  
**Selezione bin:** Binning free 2 step MacAdam's  
**Flusso luminoso (sorgente):** 515 lm / 730 lm (3000K)  
**Temperatura di funzionamento:** -20°C +50°C  
**Grado di protezione:** IP68 (non per immersione permanente)  
**Classe d'isolamento:** Classe III  
**Protezione impatto:** IK08  
**Peso:** 640 g  
**Ottiche:** 10° / 30° / 50° / (35° RGBW) / Satinato  
**Temperatura colore LED:** 2700K / 3000K / 4000K / RGBW  
**Vita media LED:** 100000 hrs  
**Rischio fotobiologico:** RG0 / RG1

PHOTOMETRICS / CURVE FOTOMETRICHE:

10° - 9 Watt

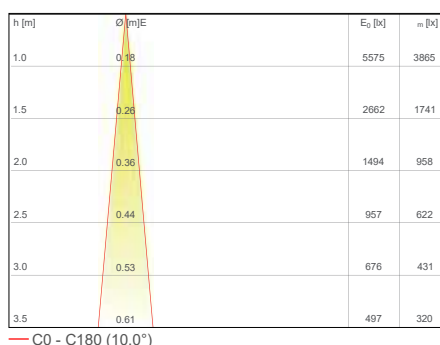

30° - 9 Watt

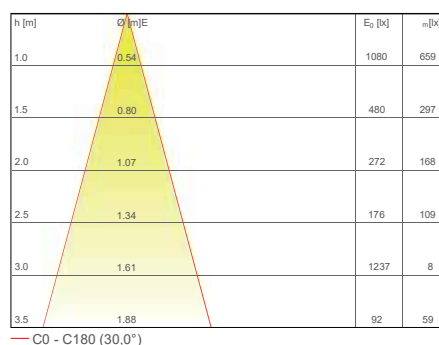

50° - 9 Watt

